

**BOLT LIST**

ITEM	QTY	PART NUMBER
1	1	TRIANGLE LOCK
2	6	M4 INSERT
3	5	M4 x 16, BUTTON HEAD, STST
4	13	M4 x 10, BUTTON HEAD, STST
5	4	M5 x 12, CHEESE HEAD, E/G
6	4	M5, SW
7	12	M4, SW
8	1	M4, FW
9	14	M4, NUT
10	4	M5, NUT

JOB NAME <b>PRODUCTION ORDER</b>	PART NUMBER <b>11-15-00032</b>			
QUANTITY	PART NAME <b>RECORD BOOK HOLDER</b>			
MATERIAL	DRAWN BY <b>ILLIDGE</b>	DATE <b>2017/06/15</b>	REVISION NO. <b>002</b>	SHEET NO. <b>1 / 11</b>

Parts List

ITEM	QTY	PART NUMBER
1	1	TRIANGLE LOCK
2	6	M4 INSERT
3	5	M4 x 16, BUTTON HEAD, STST
4	13	M4 x 10, BUTTON HEAD, STST
5	4	M5 x 12, CHEESE HEAD, E/G
6	4	M5, SW
7	12	M4, SW
8	1	M4, FW
9	14	M4, NUT
10	4	M5, NUT

REMAINING M5 NUTS AND BOLTS TO BE IN A PACK INSIDE THE BOX FOR MOUNTING ON SITE

5 B/SW/N - SAME AS OTHER SIDE

5 B/SW/N

NOTE SLOT ABOVE THE HOLE

137,2

303,34

357,11

JOB NAME <b>PRODUCTION ORDER</b>	PART NUMBER <b>11-15-00032</b>
QUANTITY	PART NAME <b>RECORD BOOK HOLDER</b>
MATERIAL	DRAWN BY <b>ILLIDGE</b>

DATE <b>2017/06/15</b>	REVISION NO. <b>002</b>	SHEET NO. <b>2 / 11</b>
---------------------------	----------------------------	----------------------------



6  
LASER, BEND

5

4

3

2

1

Table

BEND ID	BEND DIRECTION	BEND ANGLE	BEND RADIUS
1	DOWN	90	1,2
2	UP	90	1,2
3	UP	90	1,2
4	DOWN	90	1,2
5	DOWN	90	1,2
6	DOWN	90	1,2
7	DOWN	90	1,2

M4 INSERT

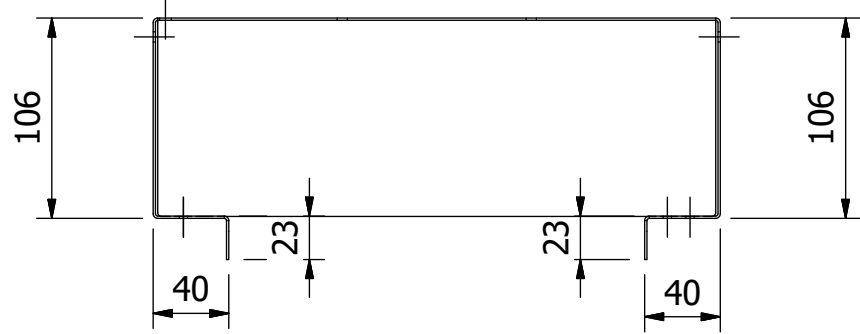
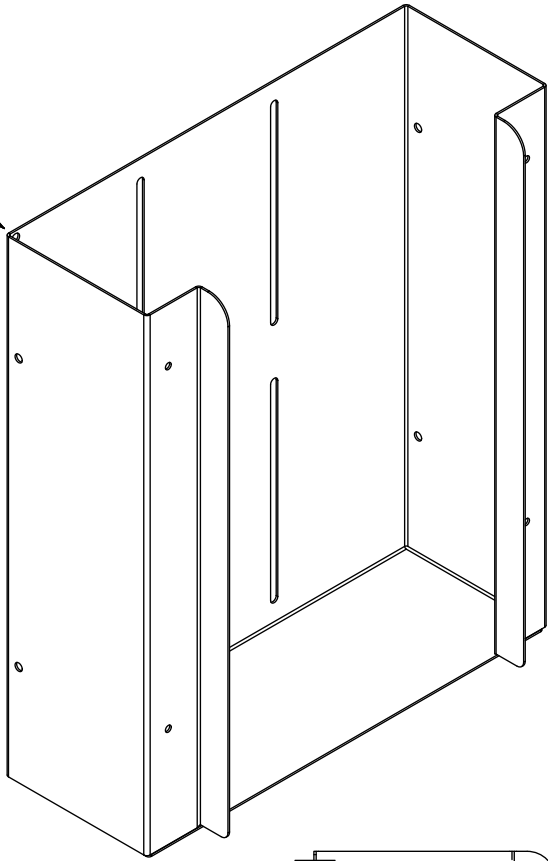

M4 INSERT

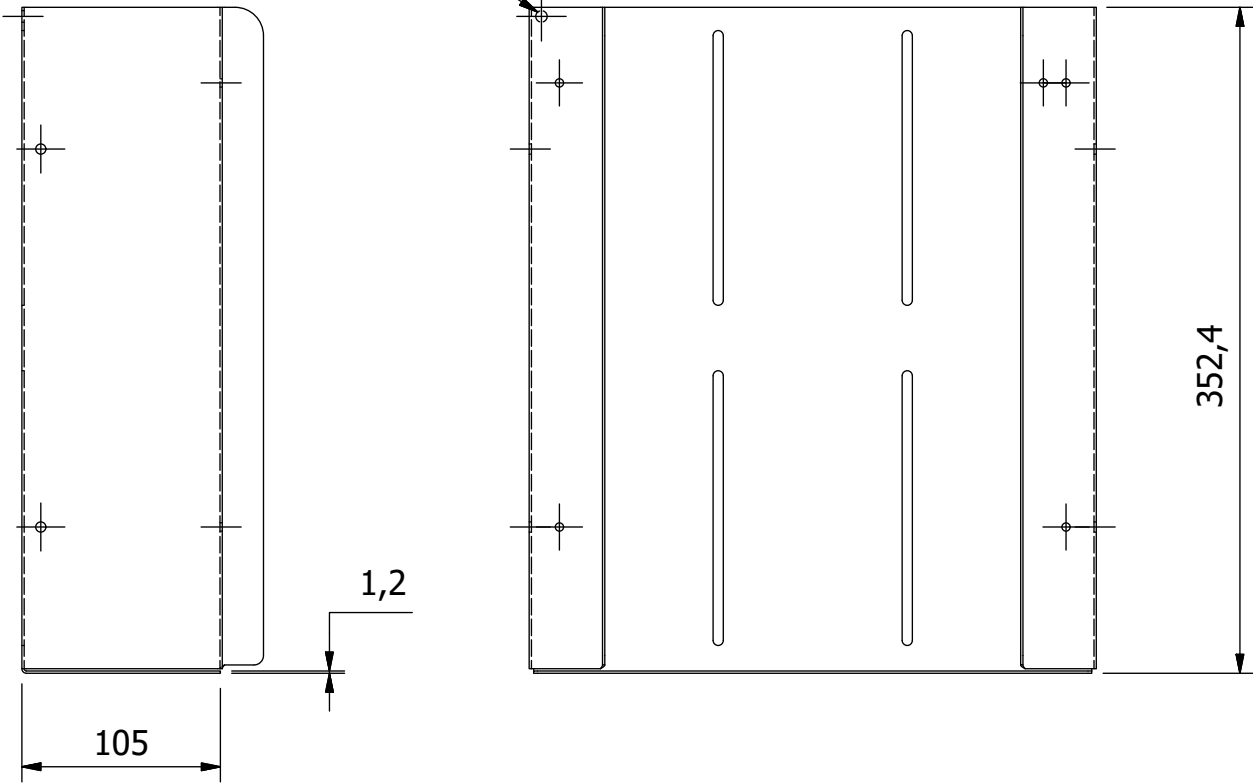

625,49

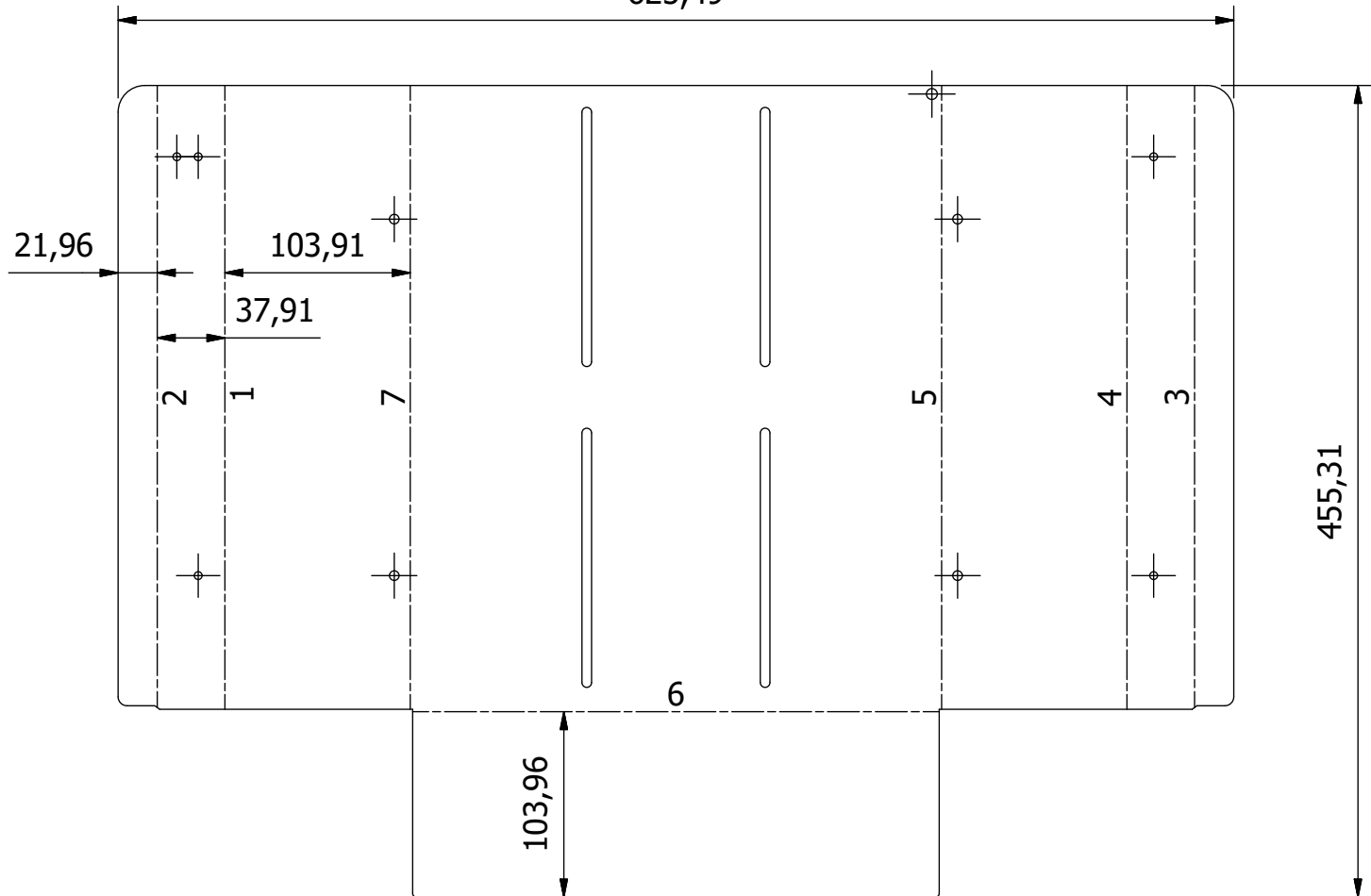

JOB NAME  
PRODUCTION ORDER 11-15-00032

PART NUMBER  
RBH BACK CASING

QUANTITY  
1 PER BOX

PART NAME  
RECORD BOOK HOLDER

MATERIAL  
1.2MM GALV

DRAWN BY  
ILLIDGE



DATE  
2017/06/15

REVISION NO.

SHEET NO.  
3 / 11

6

5

4

3

2

1

6 5 4 3 2 1  
LASER, BEND

Table			
BEND ID	BEND DIRECTION	BEND ANGLE	BEND RADIUS
1	DOWN	90	1,2
2	DOWN	90	1,2
3	DOWN	90	1,2
4	DOWN	90	1,2
5	DOWN	90	1,2

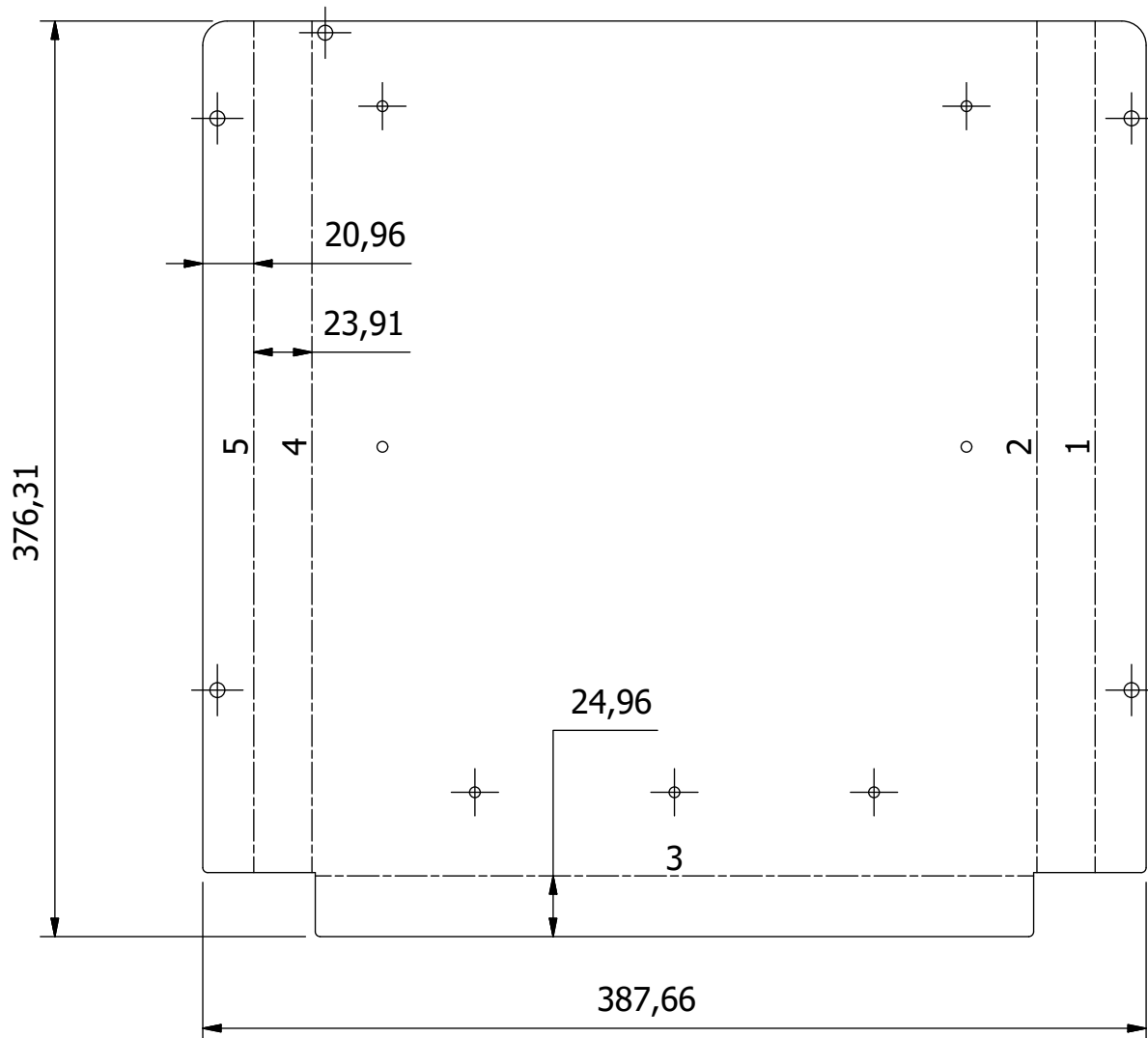
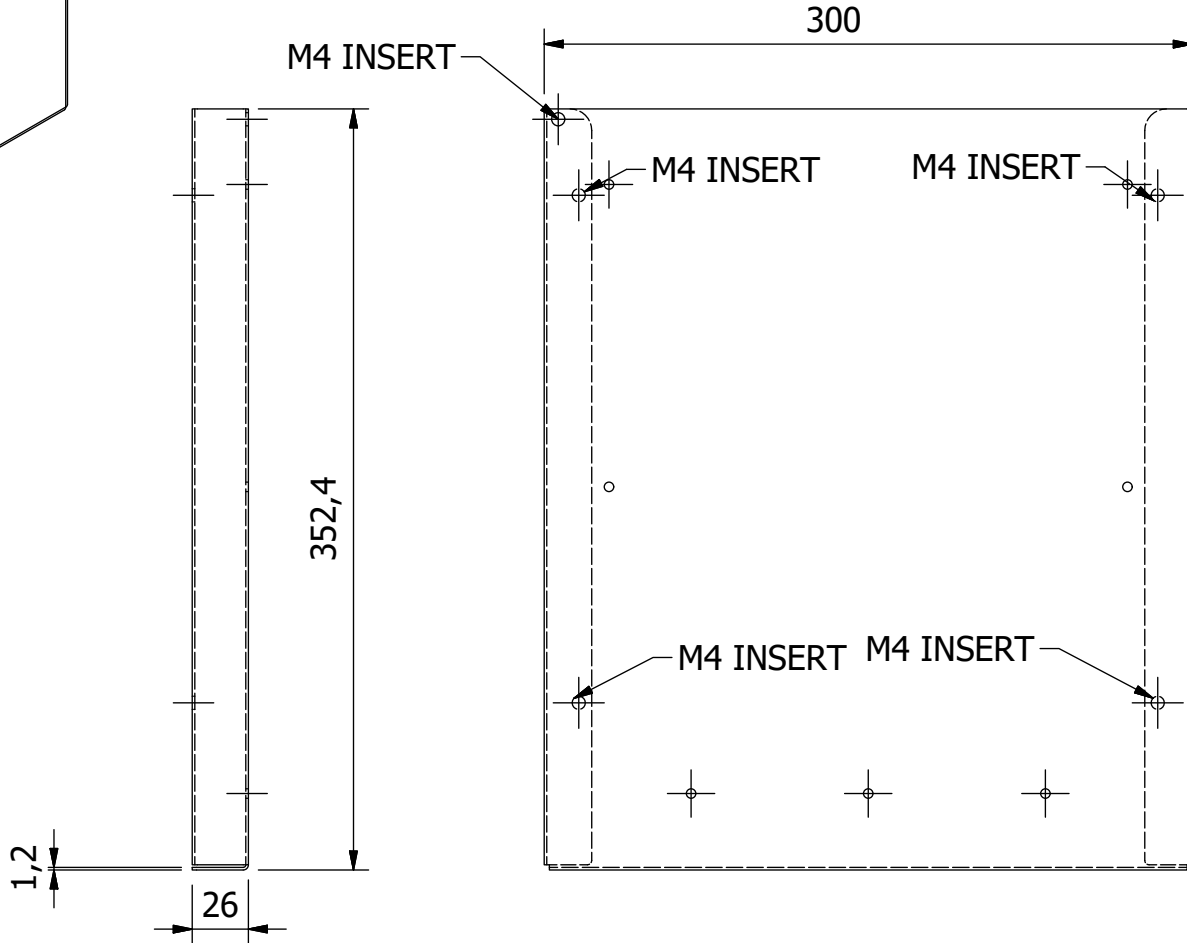
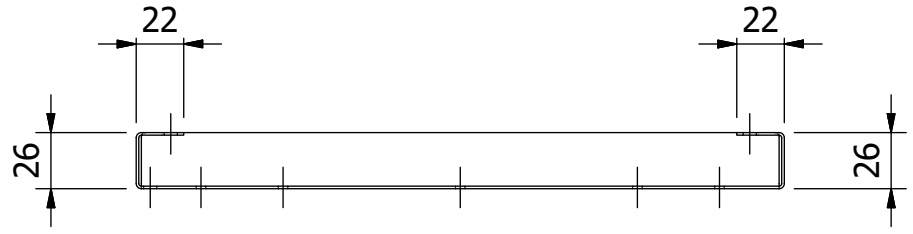
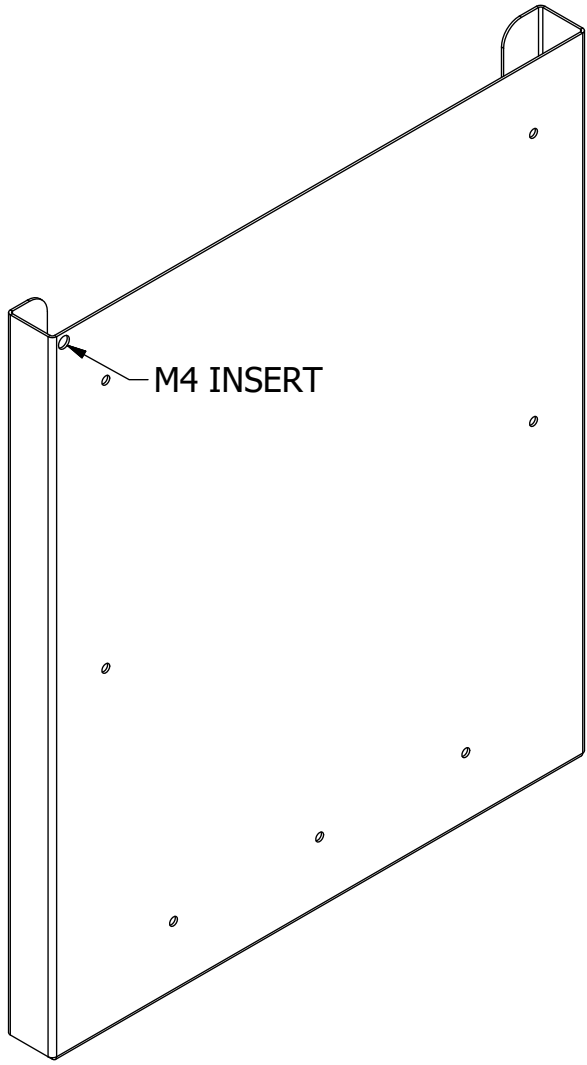

JOB NAME  
PRODUCTION ORDER 11-15-00032

PART NUMBER  
RBH FRONT CASING  
PART NAME  
RECORD BOOK HOLDER

QUANTITY  
1 PER BOX  
MATERIAL  
1.2MM GALV

DRAWN BY  
ILLIDGE



DATE  
2017/06/15

REVISION NO.

SHEET NO.  
4 / 11

6 5 4 3 2 1

6 5 4 3 2 1  
**LASER, BEND**

Table			
BEND ID	BEND DIRECTION	BEND ANGLE	BEND RADIUS
1	DOWN	90	1,2
2	UP	30	1,2
3	DOWN	90	1,2
4	DOWN	90	1,2

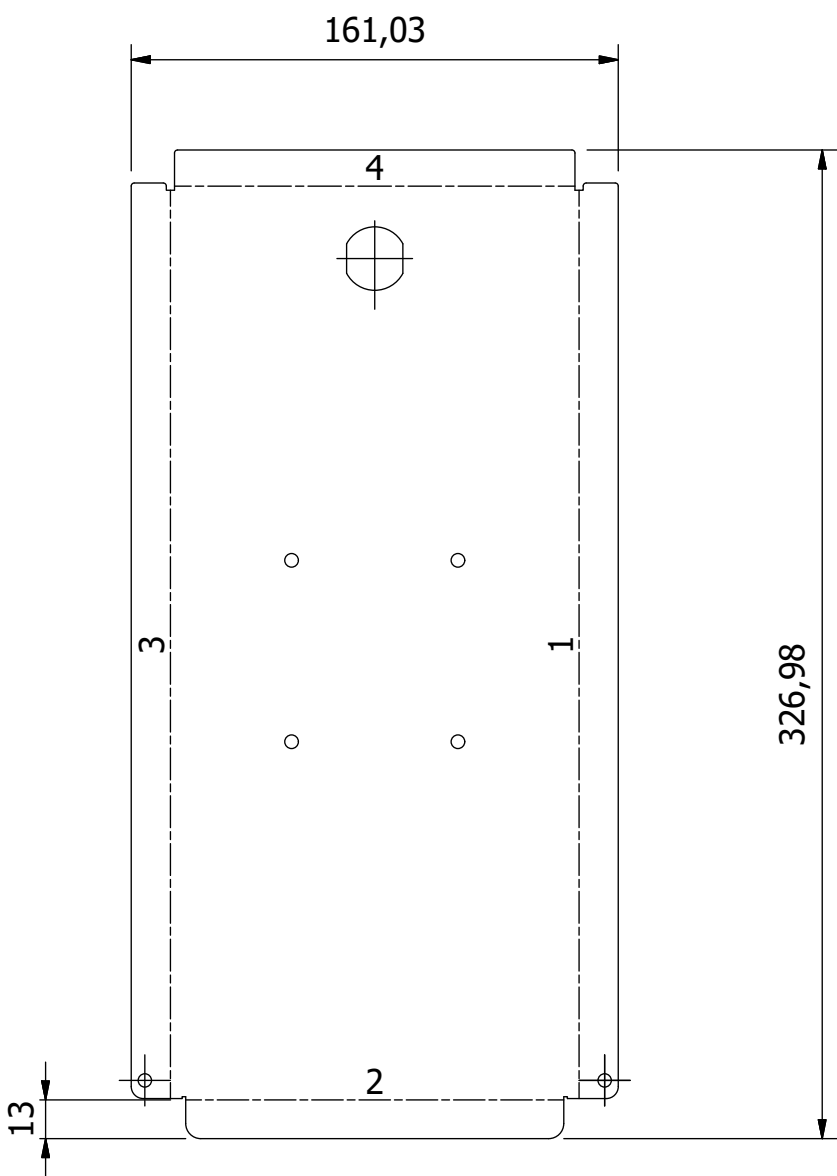
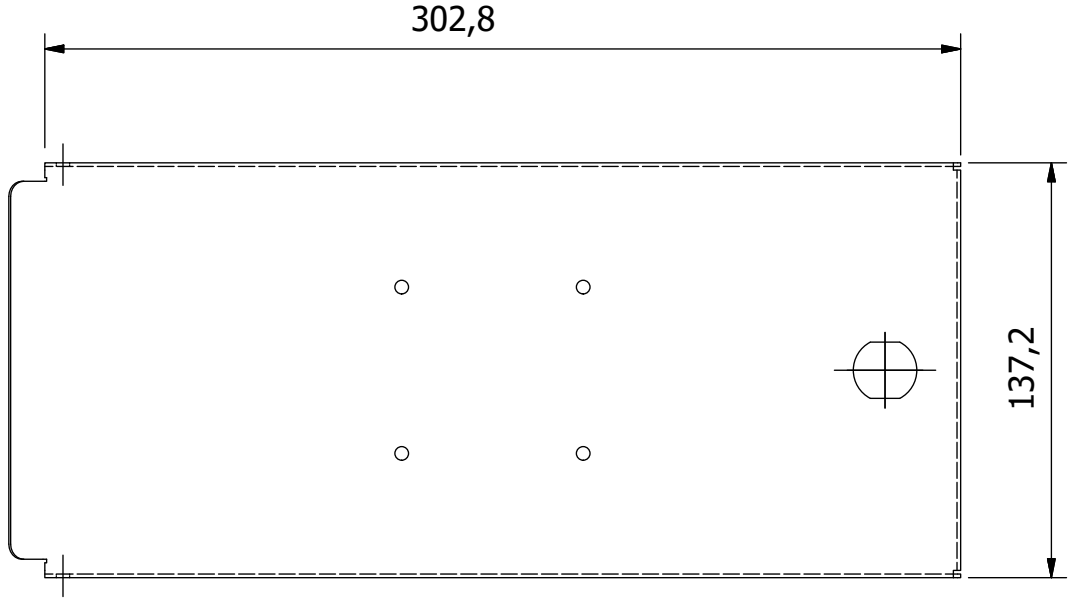
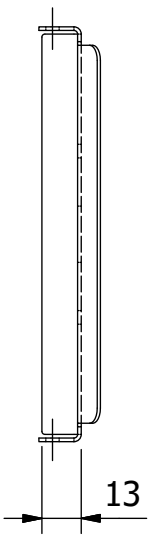
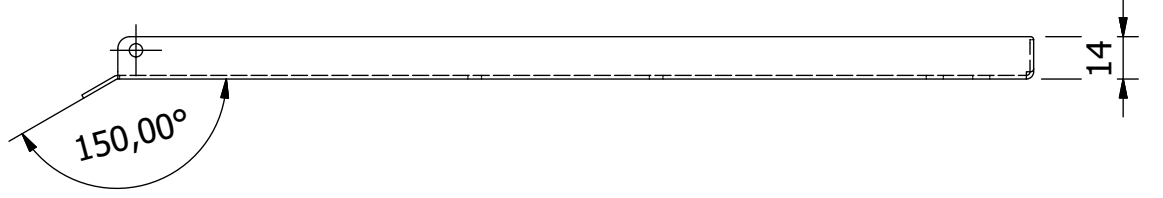
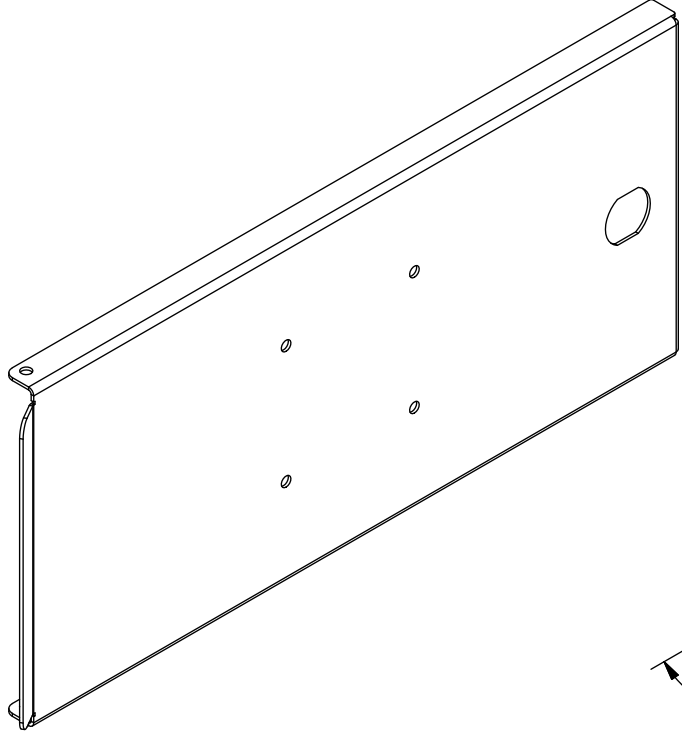

JOB NAME  
**PRODUCTION ORDER 11-15-00032**

QUANTITY  
**1 PER BOX**

MATERIAL  
**1.2MM GALV**

PART NUMBER  
**RBH LID**

PART NAME  
**RECORD BOOK HOLDER**

DRAWN BY  
**ILLIDGE**



DATE  
**2017/06/15**

REVISION NO.

SHEET NO.  
**5 / 11**

6 5 4 3 2 1  
 LASER, BEND

Table			
BEND ID	BEND DIRECTION	BEND ANGLE	BEND RADIUS
1	DOWN	90	1,2

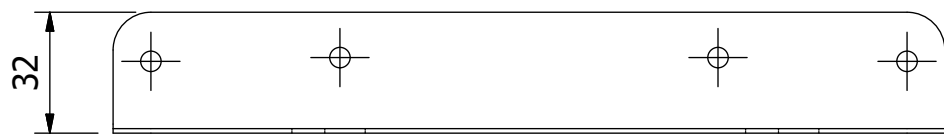
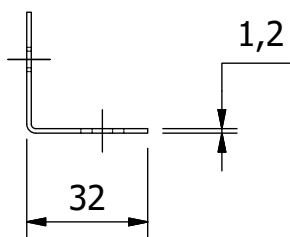
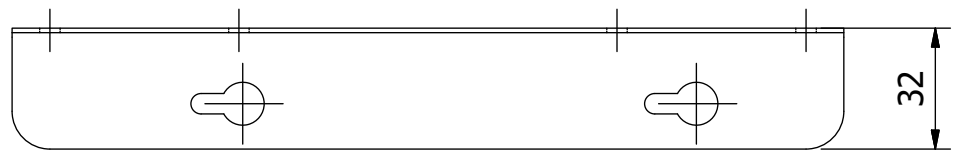
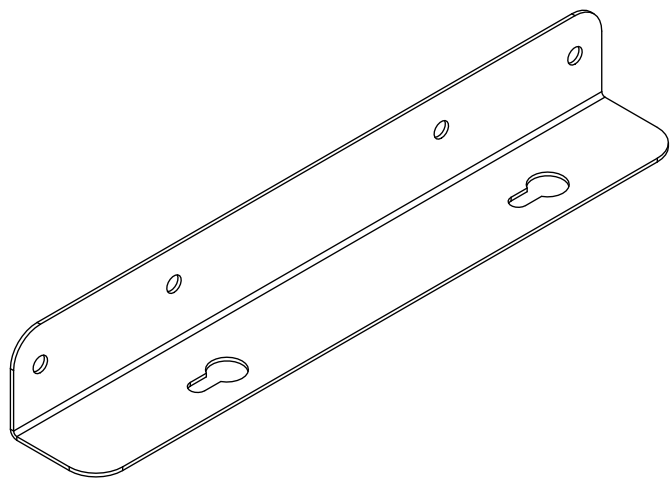
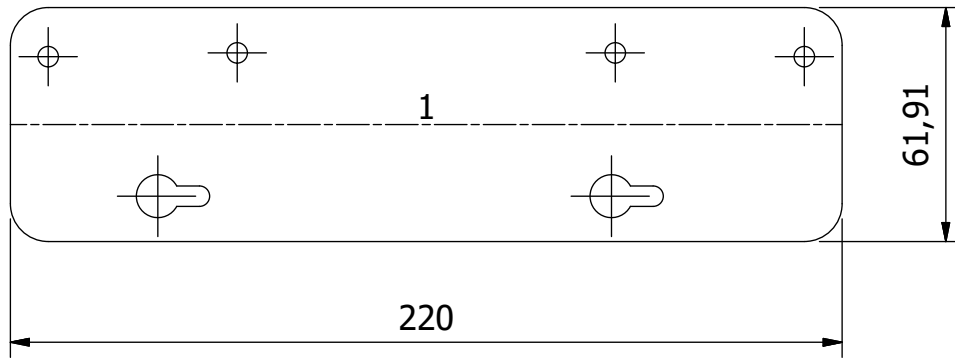

JOB NAME  
 PRODUCTION ORDER 11-15-00032

PART NUMBER  
 RBH MOUNTING BRACKET

QUANTITY  
 1 AS & 1 OPP PER BOX

PART NAME  
 RECORD BOOK HOLDER

MATERIAL  
 1.2MM GALV

DRAWN BY  
 ILLIDGE



DATE  
 2017/06/15

REVISION NO.

SHEET NO.  
 6 / 11

6 5 4 3 2 1

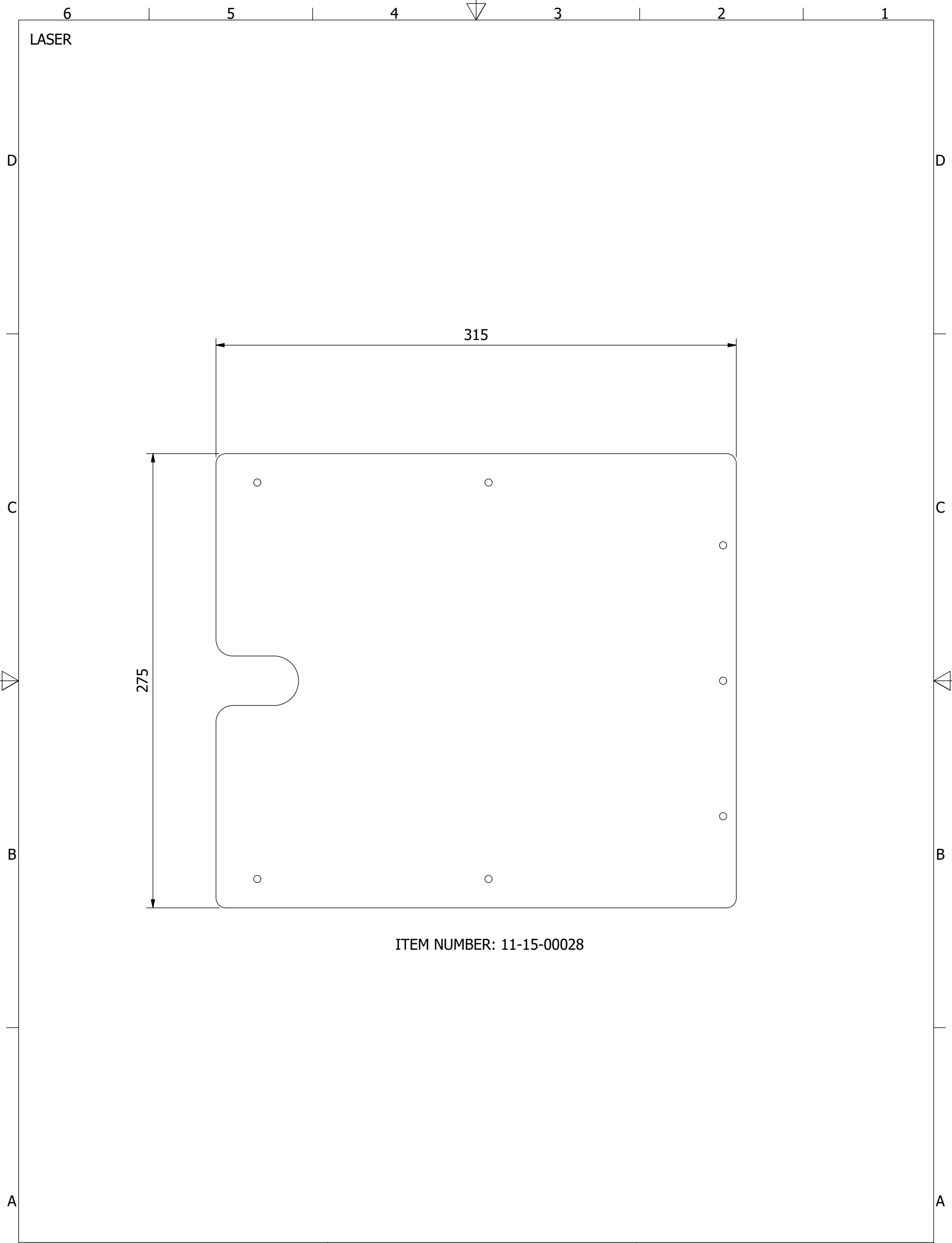

ITEM NUMBER: 11-15-00028

JOB NAME <b>PRODUCTION ORDER 11-15-00032</b>		PART NUMBER <b>RBH ANNEX PROTECTOR</b>			
QUANTITY <b>1 PER BOX</b>		PART NAME <b>RECORD BOOK HOLDER</b>			
MATERIAL <b>2mm PERSPEX</b>		DRAWN BY <b>ILLIDGE</b>		DATE <b>2017/06/15</b>	REVISION NO.
				SHEET NO. <b>7 / 11</b>	

LASER, BEND

Table			
BEND ID	BEND DIRECTION	BEND ANGLE	BEND RADIUS
1	UP	90	1,2
3	DOWN	90	1,2

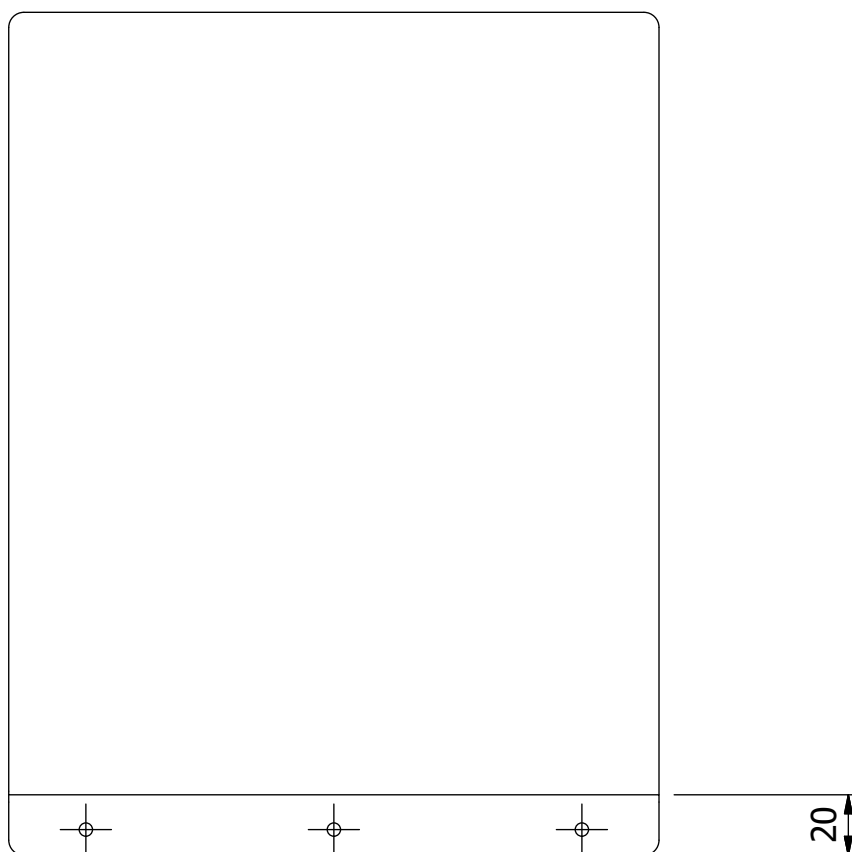
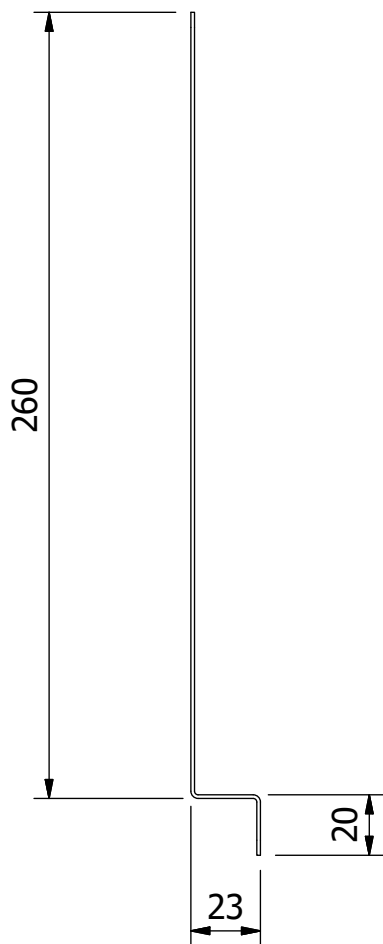
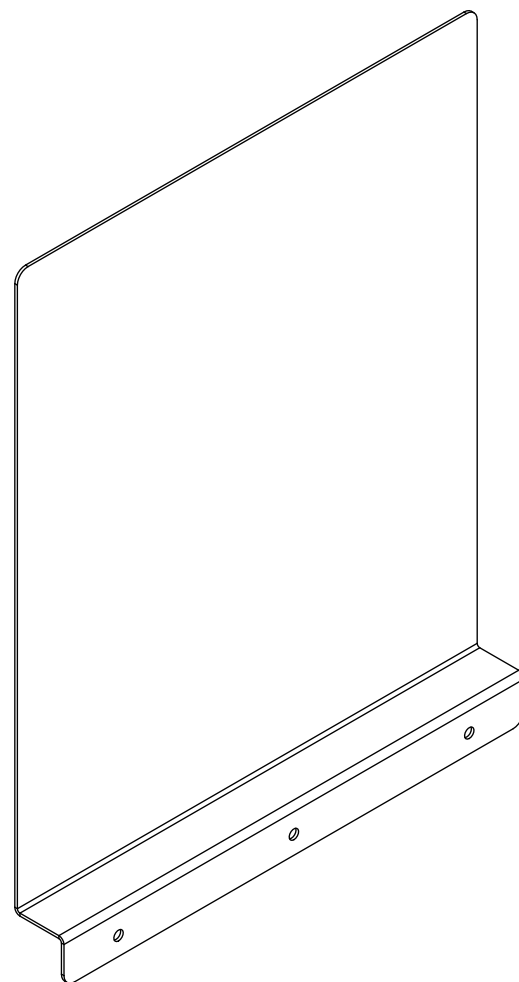
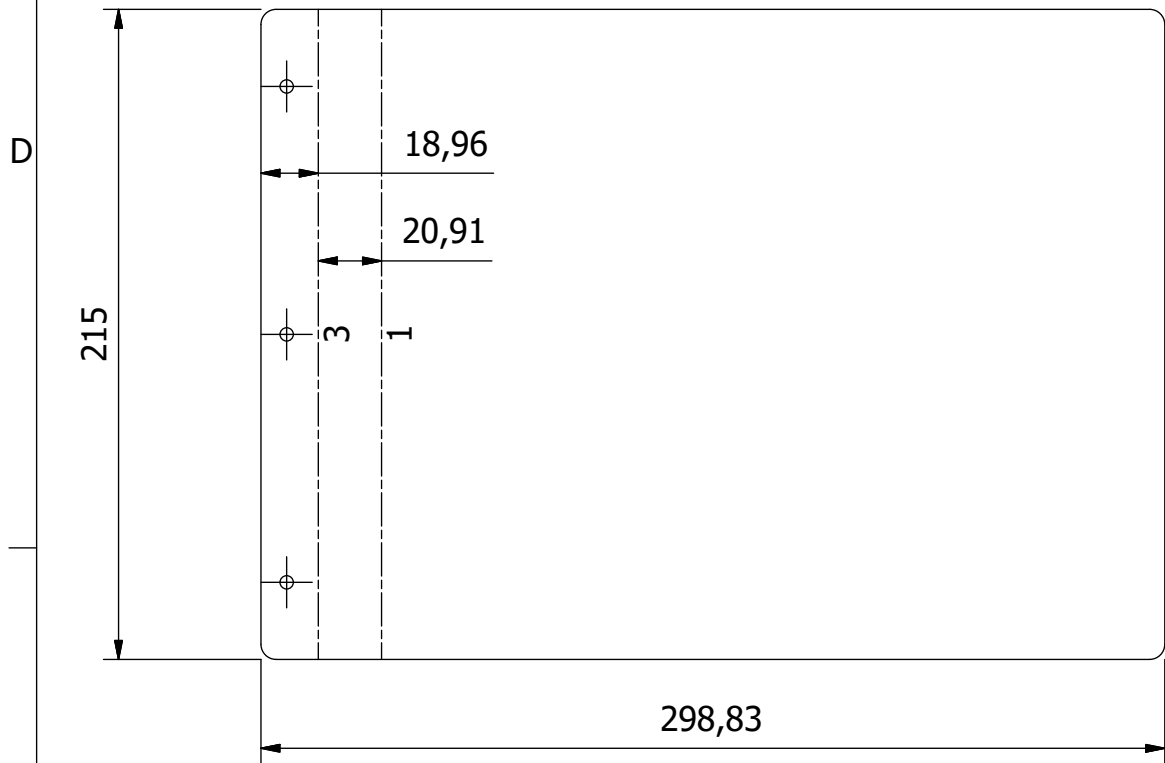

JOB NAME  
PRODUCTION ORDER 11-15-00032

PART NUMBER  
RBH BOOK HOLDER

QUANTITY  
1 PER BOX

PART NAME  
RECORD BOOK HOLDER

MATERIAL  
1.2MM GALV

DRAWN BY  
ILLIDGE



**WESANT**  
MANUFACTURING

DATE  
2017/06/15

REVISION NO.

SHEET NO.  
8 / 11

LASER, BEND

Table			
BEND ID	BEND DIRECTION	BEND ANGLE	BEND RADIUS
1	DOWN	90	1,2

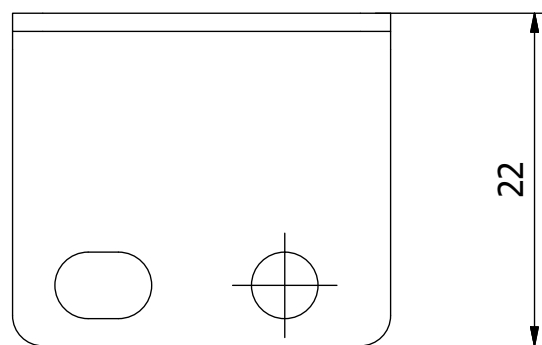
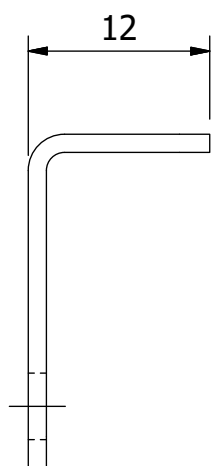
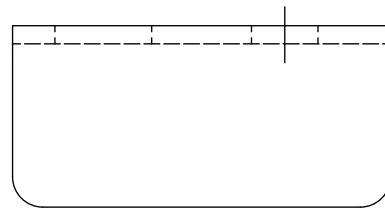
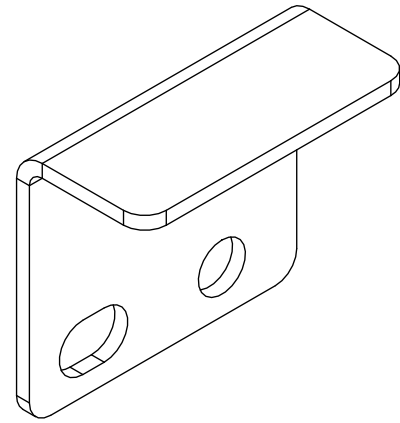
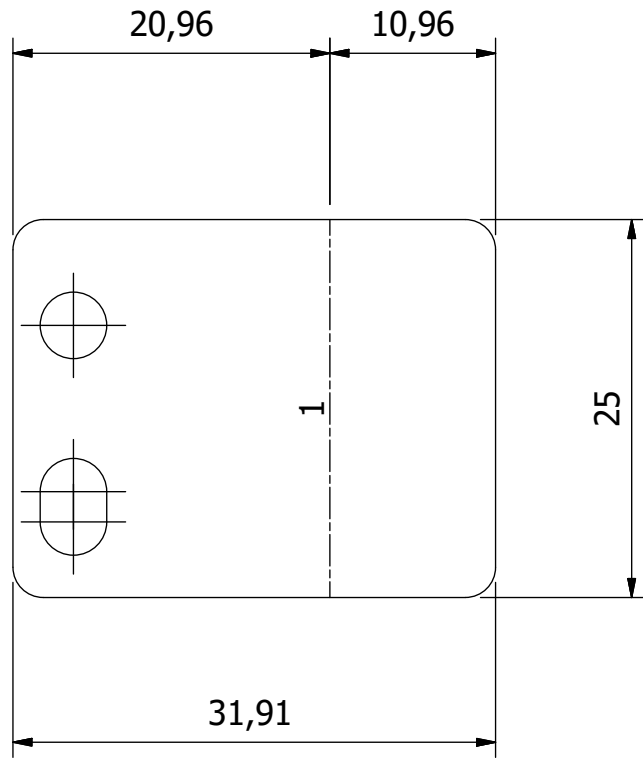

JOB NAME  
PRODUCTION ORDER 11-15-00032

PART NUMBER  
RBH LOCK LATCH

QUANTITY  
1 PER BOX

PART NAME  
RECORD BOOK HOLDER

MATERIAL  
1.2MM GALV

DRAWN BY  
ILLIDGE



**WESANT**  
MANUFACTURING

DATE  
2017/06/15

REVISION NO.

SHEET NO.  
9 / 11

LASER

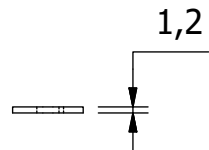
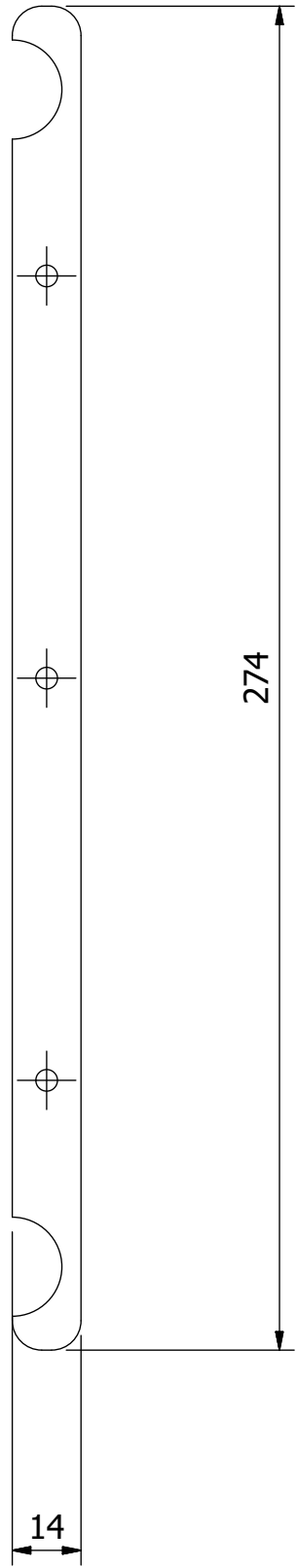
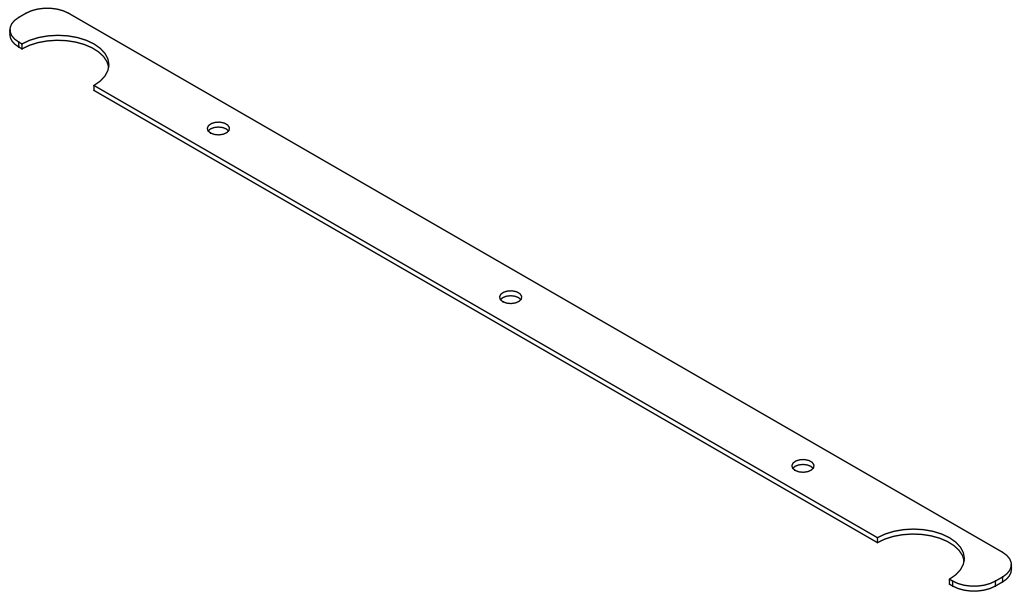

JOB NAME  
PRODUCTION ORDER 11-15-00032

PART NUMBER  
RBH HORIZONTAL SPACER

QUANTITY  
1 PER BOX

PART NAME  
RECORD BOOK HOLDER

MATERIAL  
1.2MM GALV

DRAWN BY  
ILLIDGE



DATE  
2017/06/15

REVISION NO.

SHEET NO.  
10 / 11

6

5

4

3

2

1

D

D

C

C

B

B

A

A

6

5

4

3

2

1

LASER

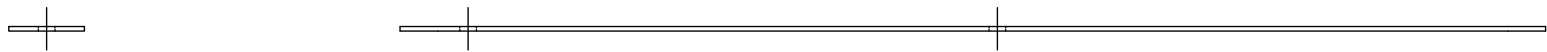
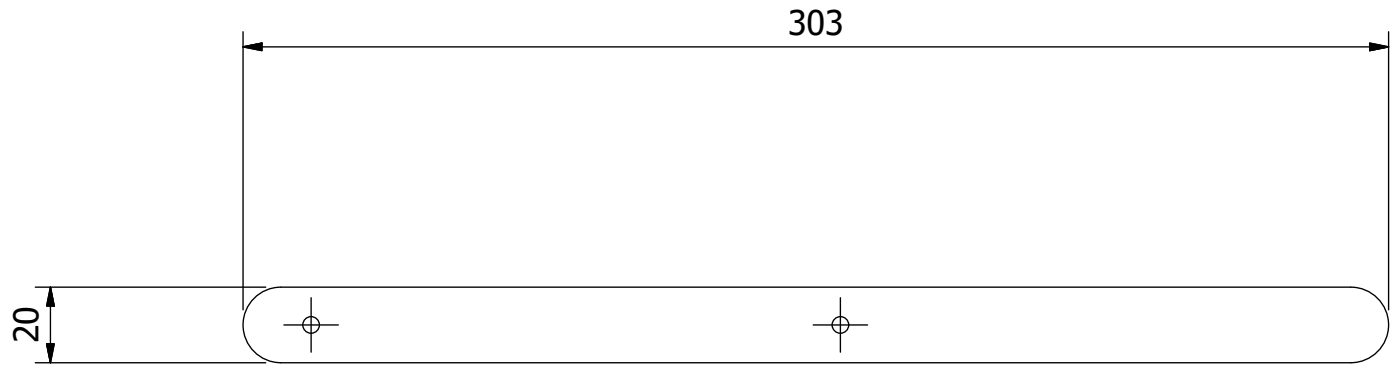
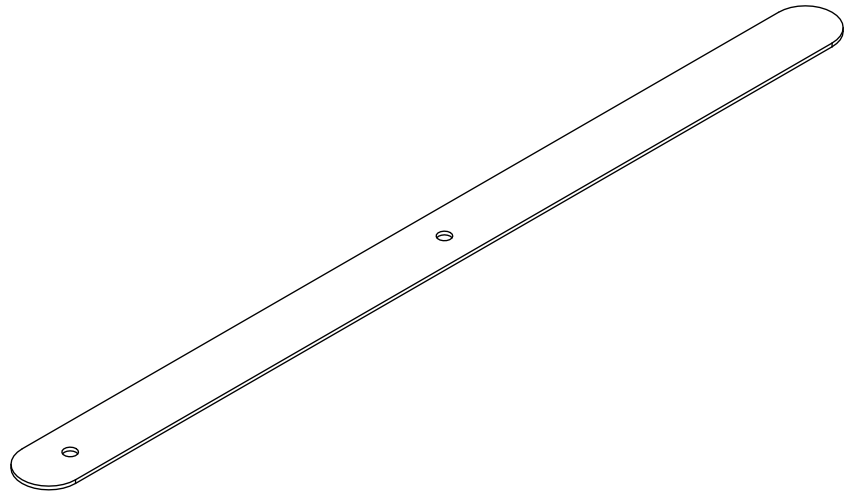

JOB NAME  
PRODUCTION ORDER 11-15-00032

PART NUMBER  
RBH VERTICAL SPACER

QUANTITY  
2 PER BOX

PART NAME  
RECORD BOOK HOLDER

MATERIAL  
1.2MM GALV

DRAWN BY  
ILLIDGE



DATE  
2017/06/15

REVISION NO.

SHEET NO.  
11 / 11